

PN 10 Volute Casing Centrifugal Pumps

SERIES NIM of the Inline Design
SERIES NAM with Axial Intake

for Pedestal or Wall Mounting

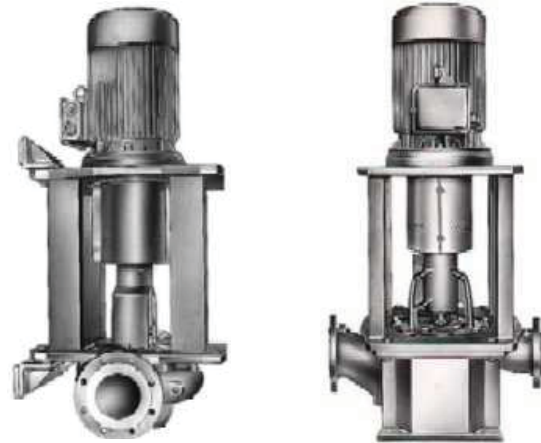

NAM-W

NIM-S

Application

For handling fresh water, sea water, condensate, oils, brines, lyes etc. The fluids to be pumped must not contain any abrasive particles nor chemically attack the construction materials of the pumps.

Main fields of application

In shipbuilding: As general service and fire pump, bilge, ballast and cooling water pump as well as sea water pump.

Type of construction

Single-stage, single-flow volute casing centrifugal pump. NIM type of construction: Volute casing of the inline design. NAM type of construction: Volute casing with axial intake and radial outlet. Nominal capacities according to DIN 24 255.

Pump casing and bearing unit are connected with the driving motor by means of a pump bracket. Feet at the lower flange of the pump bracket allow vertical pedestal installation. Laterally arranged brackets permit vertical wall mounting. General application of spacer couplings allow easy dismantling of the bearing unit including impeller without removing the volute casing, pipelines and driving motor. Readjusting of the coupling is not necessary as the pump and driving motor are exactly centered in the pump bracket, i.e. intermediate ring.

All screw connections are by means of hexagonal screws and hexagonal nuts so that even after repeated painting (shipbuilding), proper loosening of same will be ensured.

The requirements of DIN 31001 "Contact Protection" are complied with.

Attention: In the pump denomination, the standard nominal width as per DIN 24 255 on the delivery side is applied as this nominal width, in connection with the impeller diameter, is also a characteristic size for the hydraulic performance of the pump.

With the NIM type of construction, the respective actual nominal width on the suction and delivery sides are greater by one nominal width than as per DIN 24 255 (e.g. NIM 80–250 with $DN_s = 125$ mm and $DN_d = 100$ mm).

Branch position/Flanges

With NIM: Suction and delivery branches in one line, opposite.

With NAM: Suction branch axial, delivery branch radial.

Flanges: up to DN 150 as per DIN 2533
for DN 200 and above as per DIN 2532

Shaft sealing

By uncooled stuffing boxes with internal sealing. Packing rings of Teflon-impregnated white asbestos yarn.

By uncooled, unbalanced, maintenance-free mechanical seal.

Material design:

Rotary seal	hard carbon
Stationary seal	oxide ceramics
O-rings	fluoroelastomer (FPM) ①
Metal parts	stainless steel

① With water above 100°C EP-rubber.

Bearing/Lubrication

Two grease-lubricated grooved ball bearings as per DIN 625 in the bearing bracket.

Upper temperature ② and pressure limits

Applicable to all three material designs.

Admissible temperature of the fluid to be pumped with uncooled stuffing box	125°C
uncooled mechanical seal	140°C
Admissible internal pressure	10 bar
Admissible inlet pressure	Inlet pressure plus max. delivery head must not exceed the admissible internal pump pressure.

② The admissible temperatures apply to water. In case of other fluids to be pumped, the temperature limits may change.

Shaft coupling/Contact protection

Flexible shaft coupling with spacer (dismounting-type coupling).

A contact protection as per DIN 31001 is also supplied.

Exchangeability

Simple spare parts stockage owing to the unit assembly principle. For both types of construction, only three bearing units (shaft sizes) are required.

Drive

By means of three-phase motors, surface-cooled V1 type of construction, enclosures IP 44 and IP 54 according to IEC standards, class B insulation. Performances and main dimensions as per DIN 42 677.

Or by means of three-phase motors for naval operation, surface-cooled, V1 type of construction, enclosures IP 44 and IP 54 or IP 23, class B insulation.

Combination of components

The table on page 3 shows the combination possibilities of components of all NIM and NAM sizes.

It is of particular advantage that within one bearing bracket size for all pump sizes the shaft and the casing cover with stuffing box and/or mechanical seal are designed of identical construction.

Connections

The following connections are always provided:

- A1 Filling
or control pressure extraction for automatic aspirator
- B1 Drainage
- D8 Leakage drain
- E3 Venting
- E4 Venting with automatic aspirator
- M1, M2 Pressure gauge

Automatic aspirator A 25 A

For data, please refer to back cover of the brochure.

Abbreviation

Abbreviation system of a NIM or NAM pump

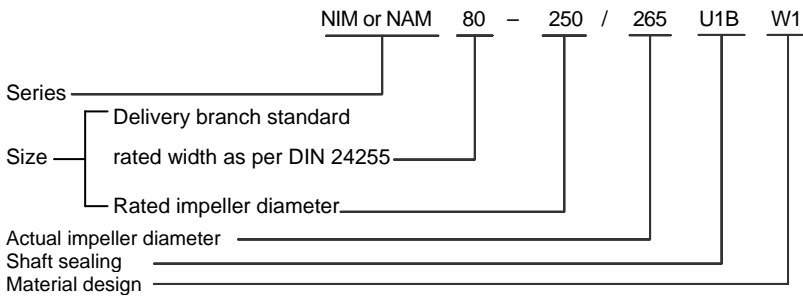

This abbreviation is entered on the rating plate.

Materials

Denomination	Part No.	Material designs				
		W1	W2	W3	W18	W19
Volute casing	102.11	GG-25	GG-25	G-CuAl 10Ni	GG-25	GG-25
Casing cover	161.5 a. 161.23	GG-25	GG-25	G-CuAl 10Ni	GG-25	GG-25
Shaft	211.1	1.4021/1.7139②	1.4021/1.7139②	1.4401/1.7139②	1.4401/1.7139②	1.4401/1.7139②
Impeller	230.1	GG-20	G-CuAl 10Ni	G-CuAl 10Ni	G-CuAl 10Ni	GG-20
Bearing bracket	330.1	GG-25	GG-25	GG-25	GG-25	GG-25
Pump bracket	346.2	steel welded	steel welded	steel welded	steel welded	steel welded
Stuffing box gland	452.1	GG-25	GG-25	G-CuAl 10Ni	GG-25	GG-25
Split ring	① 502.1/502.2	GC/GZ-CuSn12	GC/GZ-CuSn12	GC/GZ-CuSn12	GC/GZ-CuSn12	GC/GZ-CuSn12
Intermediate ring	509.2	GG-25	GG-25	G-CuAl 10Ni	GG-25	GG-25
Distance sleeve	525.1	GG-25	GG-25	GC/G2-CuSn12	GG-25	GG-25
Screws and nuts coming into contact with the fluid to be pumped		stainless steel	stainless steel	stainless steel	stainless steel	stainless steel

① Split rings against surcharge.

② On the pump side (in contact with fluid) 1.4021 or 1.4401/on the motor side 1.7139.
Shaft of material 1.4401/1.7139 against surcharge

Table Combination of Components

The table below shows the combination possibility of structural and component parts of sizes NIM and NAM

Bearing bracket size	Pump sizes		Bearing bracket	Shaft	Casing cover		Volute casing	Impeller	Pump spacer	Pump foot	Bracket (for wall mounting)	Clutch guard	Distance ring (under clutch guard)
	① NIM	NAM			Stuffing box	Mech. seal							
470	65–250		1	1	1	1	1	1	1	1	1	1	
		65–250					2						
	65–315						3	2	2	2	3		
		65–315					4						
	65–400						5	3	3	3	4		
	80–200						7	4	1	1	1		
	80–250						9	5					
		80–250					10						
	80–315						11	6	2	2	3		
		80–315					12						
	100–200						13	7	1	1			
	100–250						15	8			1-2②		
		100–250					16						
	100–315						17	9	2	2	3		
		100–315					18						
	125–250						19	10	1	1	1		
		125–250					20						
530	80–400		2	2	2	2	21	11	6	6	6	2	
	100–400						22	12					
	125–315						23	13	5	5	5		
	125–400						24	14	6	6	6		
	150–250						25	15	5	4	5		
	150–315						26	16		5			
	150–400						27	17	6	6	6		
	200–250						28	18	4	4	5		
585	200–315		3	3	3	3	29	19	7	7	7-8②	3	
	250–315						30	20					
	250–400						31	21					

Within the vertical column, identical parts with identical number are exchangeable.

① With series NIM, each one of the actual nominal widths on the suction and delivery sides is greater by one nominal width.

 ② Component: Bracket No. 2 with installation of an electric motor with outside flange diameter 660 mm.
 Bracket No. 8 with installation of an electric motor with outside flange diameter 800 mm.

**Performance graph
1450 1/min**

Sizes: NIM

- 65-250
- 65-315
- 65-400
- 80-200
- 80-250
- 80-315
- 80-400
- 100-200
- 100-250
- 100-315
- 100-400
- 125-250
- 125-315
- 125-400
- 150-250
- 150-315
- 150-400
- 200-250
- 200-315
- 250-315
- 250-400

Sizes: NAM

- 65-250
- 65-315
- 80-250
- 80-315
- 100-250
- 100-315
- 125-250

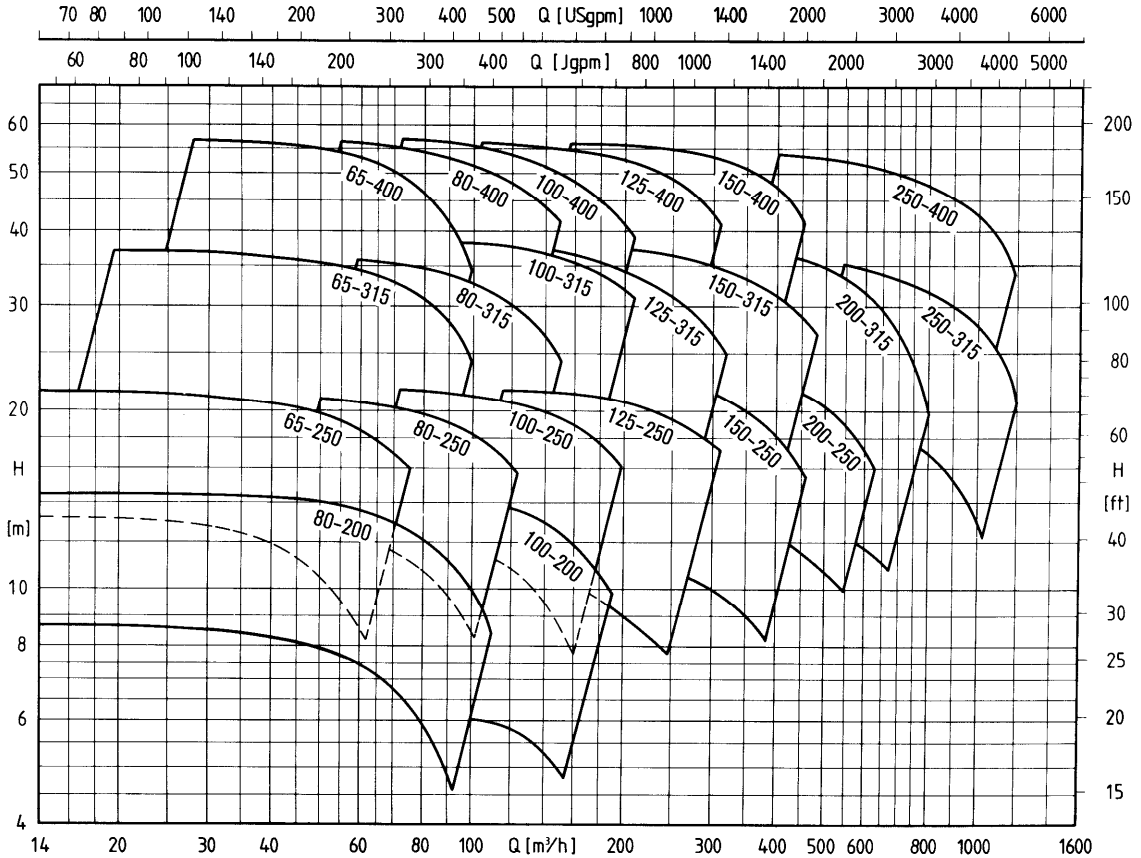

**Performance graph
2900 1/min**

Sizes: NIM

- 65-250
- 80-200
- 80-250
- 100-200
- 100-250
- 125-250

Sizes: NAM

- 65-250
- 80-250
- 100-250
- 125-250

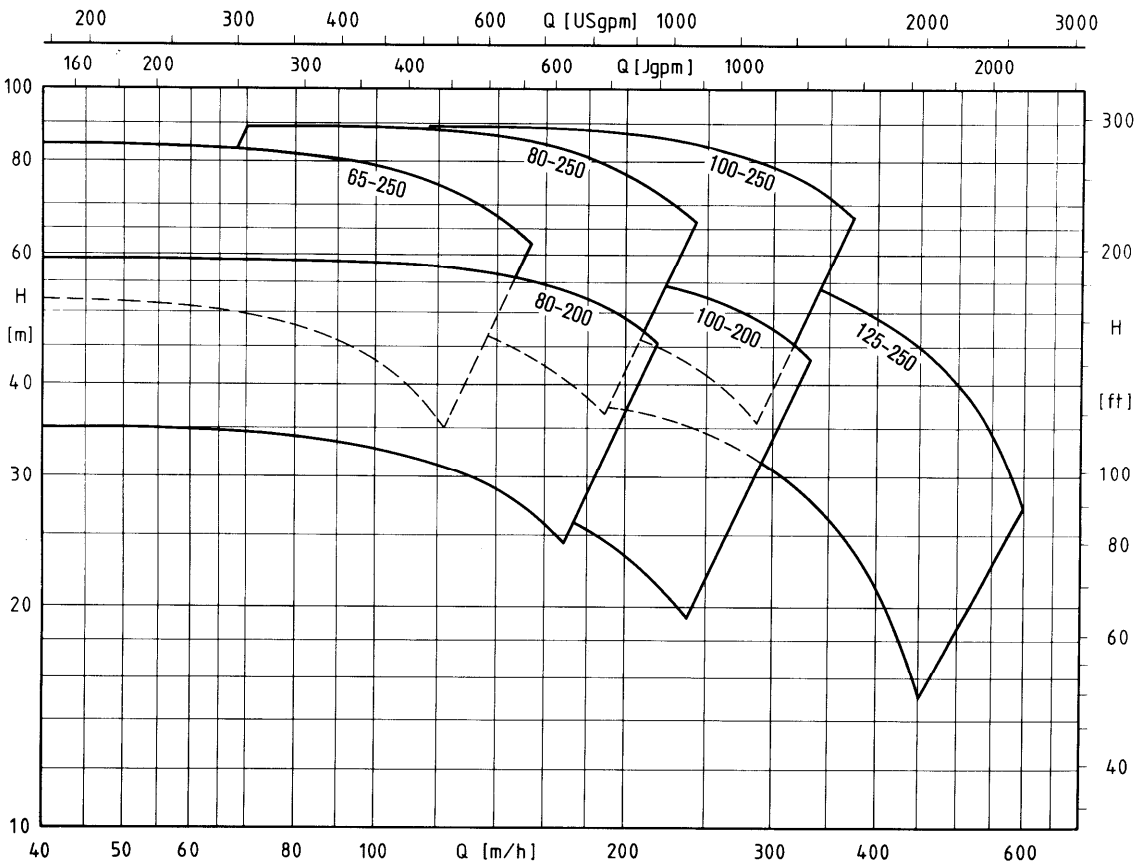

Exact performance data to be taken from the individual characteristic curves.
For the smaller performance range, please refer to series NISM.

Performance graph
1750 1/min

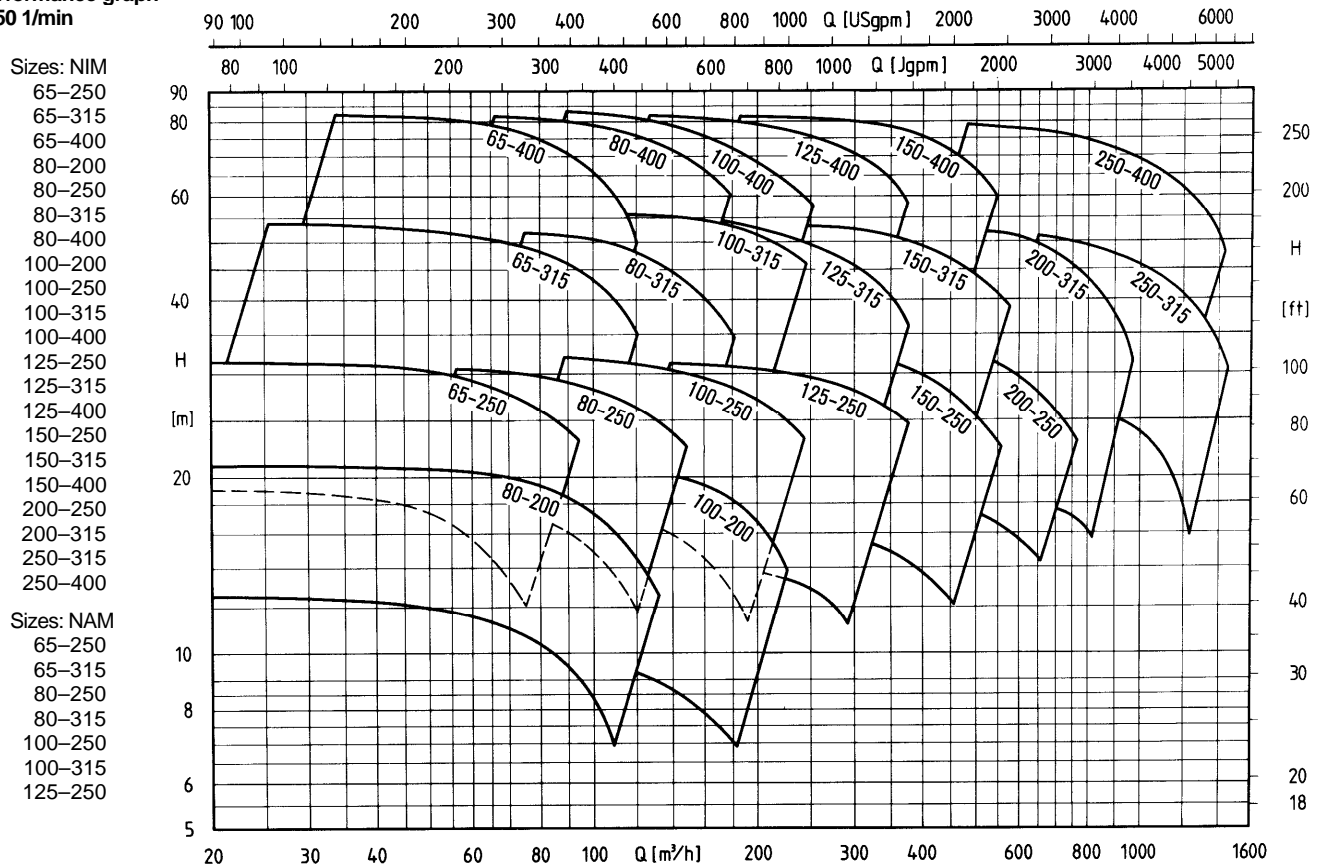

Performance graph
3500 1/min

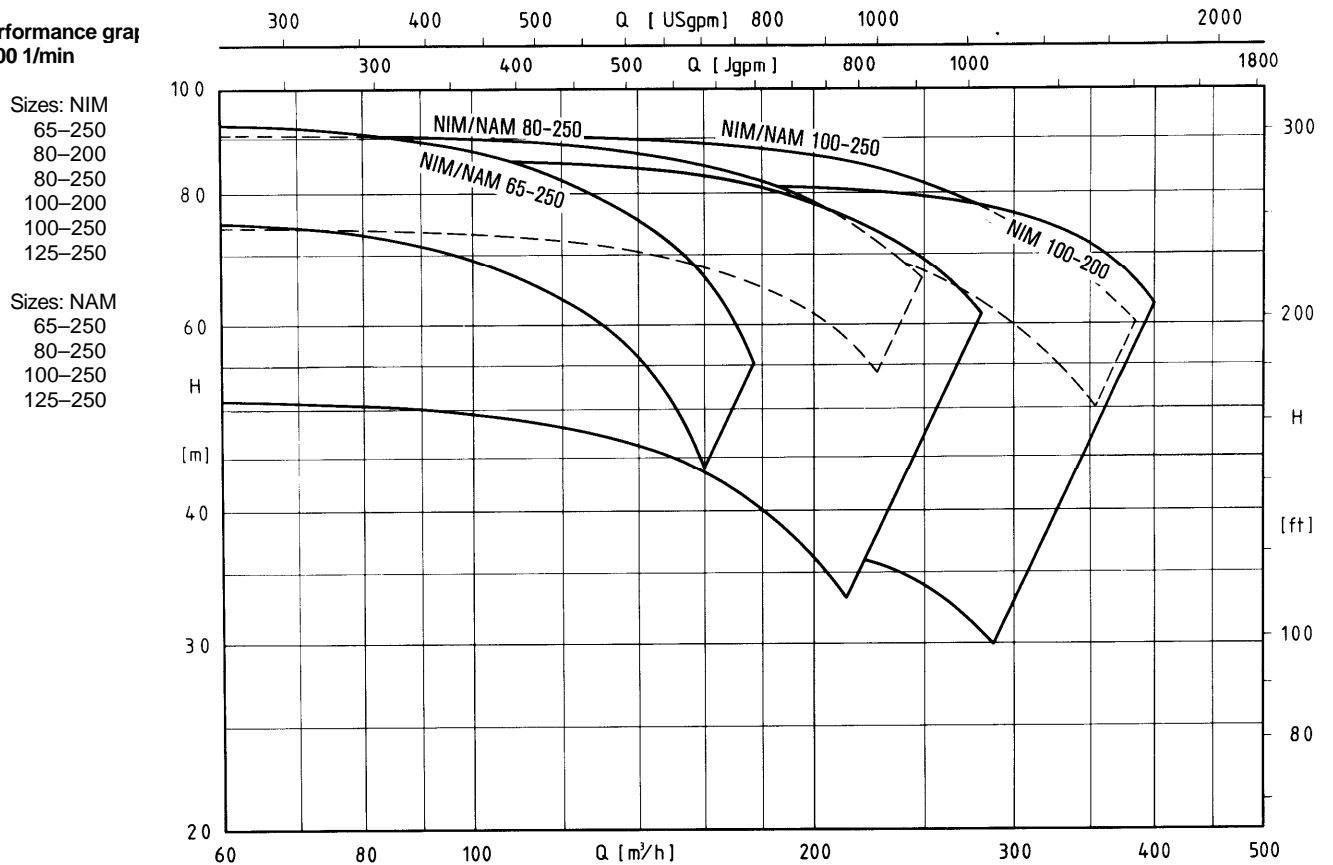

Exact performance data to be taken from the individual characteristic curves.
For the smaller performance range, please refer to series NISM.

Sectional drawing Pedestal Mounting Type

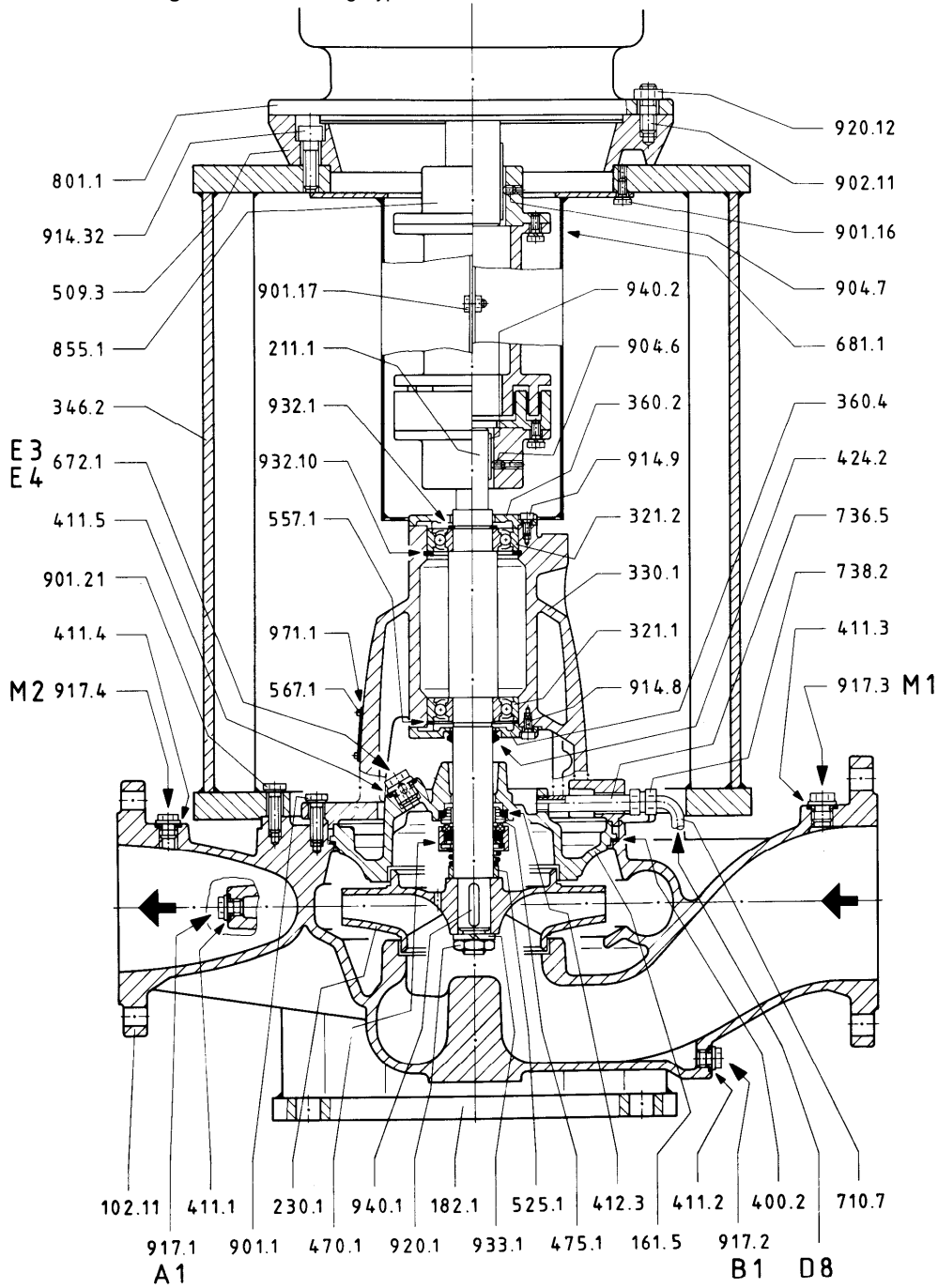

Shaft sealing: Uncooled, unbalanced mechanical seal, internal flushing
 Abbreviation: U3D

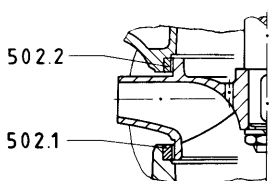

Design with split rings V2 (surcharge)

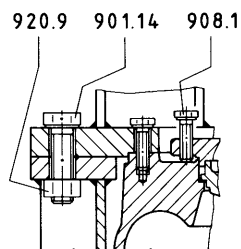

Fastening of pump feet to pump bracket

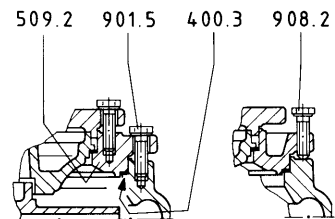

Design with intermediate ring

View Mounting Type

List of components for pedestal mounting and wall fastening

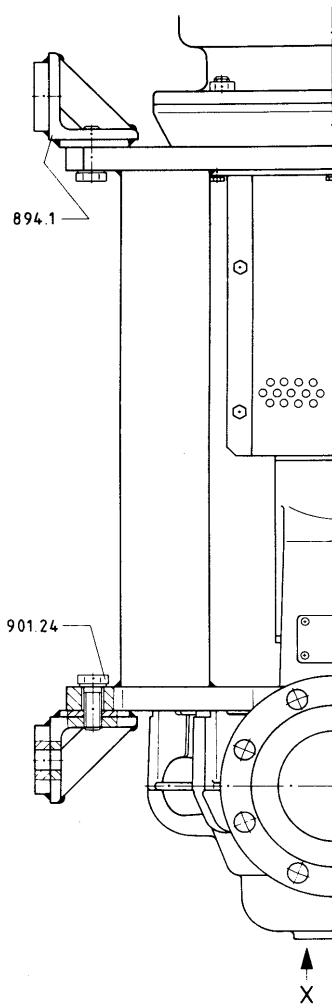

View X

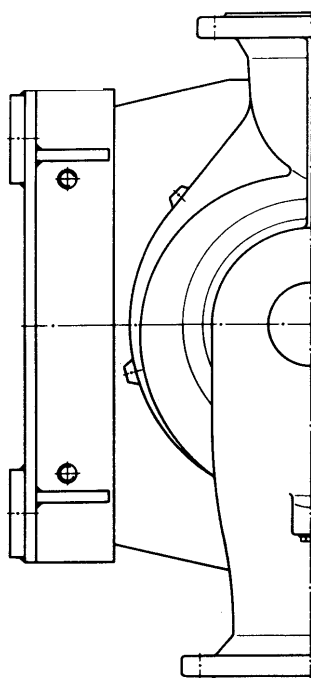

Denomination	Part No.	Denomination	Part No
Volute casing	102.11	Venting screw	672.1
Casing cover	161.5	Coupling guard	681.1
Casing cover	161.23	Pipe	710.7
Pump foot	182.1	Nipple joint	736.5
Shaft	211.1	Screw-on type union	738.2
Impeller	230.1	Motor	801.1
Grooved ball bearing	321.1	Dismounting-type coupling	855.1
Grooved ball bearing	321.2	Bracket	894.1
Grooved ball bearing	321.3	Hexagonal screw	901.1
Grooved ball bearing	321.4	Hexagonal screw	901.5
Bearing bracket	330.1	Hexagonal screw	901.14
Pump spacer	346.2	Hexagonal screw	901.16
Bearing cover	360.2	Hexagonal screw	901.17
Bearing cover	360.4	Hexagonal screw	901.21
Bearing cover	360.5	Hexagonal screw	901.24
Gasket	400.2	Locking screw	902.4
Gasket	400.3	Locking screw	902.11
Washer	411.1	Stud	904.6
Washer	411.2	Stud	904.7
Washer	411.3	Forcing screw	908.1
Washer	411.4	Forcing screw	908.2
Washer	411.5	Socket head cap screw	914.8
O-ring	412.3	Socket head cap screw	914.9
V-ring	424.2	Socket head cap screw	914.32
Gland	452.1	Threaded plug	917.1
Seal ring	458.1	Threaded plug	917.2
Packing ring	461.1	Threaded plug	917.3
Mechanical seal	470.1	Threaded plug	917.4
Stationary seal ring	475.1	Hexagonal nut	920.1
Casing wear ring	502.1	Hexagonal nut	920.2
Casing wear ring	502.2	Hexagonal nut	920.9
Intermediate ring	509.1	Hexagonal nut	920.12
Nilos ring	516.1	Circlip	932.1
Nilos ring	516.2	Circlip	932.10
Distance sleeve	525.1	Spring washer	933.1
Support disc	551.3	Key	940.1
Support disc	551.7	Key	940.2
Ball bearing		Cup spring	952.3
balancing disc	557.1	Rating plate	971.1
Blind rivet	567.1		

Connections

- A1 Filling or control pressure extraction for automatic aspirator
- B1 Drainage
- D8 Leakage drain
- E3 Venting
- E4 Venting with automatic aspirator
- M1 Pressure gauge
- M2 Pressure gauge

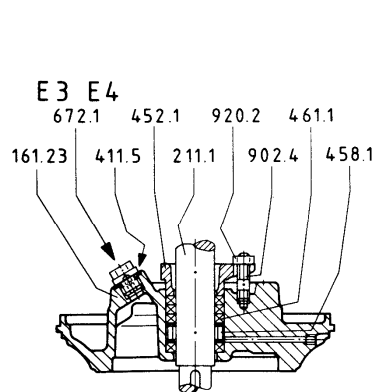

Stuffing box with internal sealing U1B

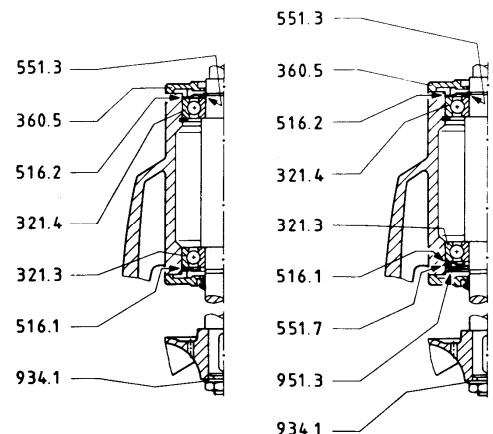

Design for bearing and impeller safety mechanism with bearing bracket sizee

Sectional drawing Pedestal Mounting Type

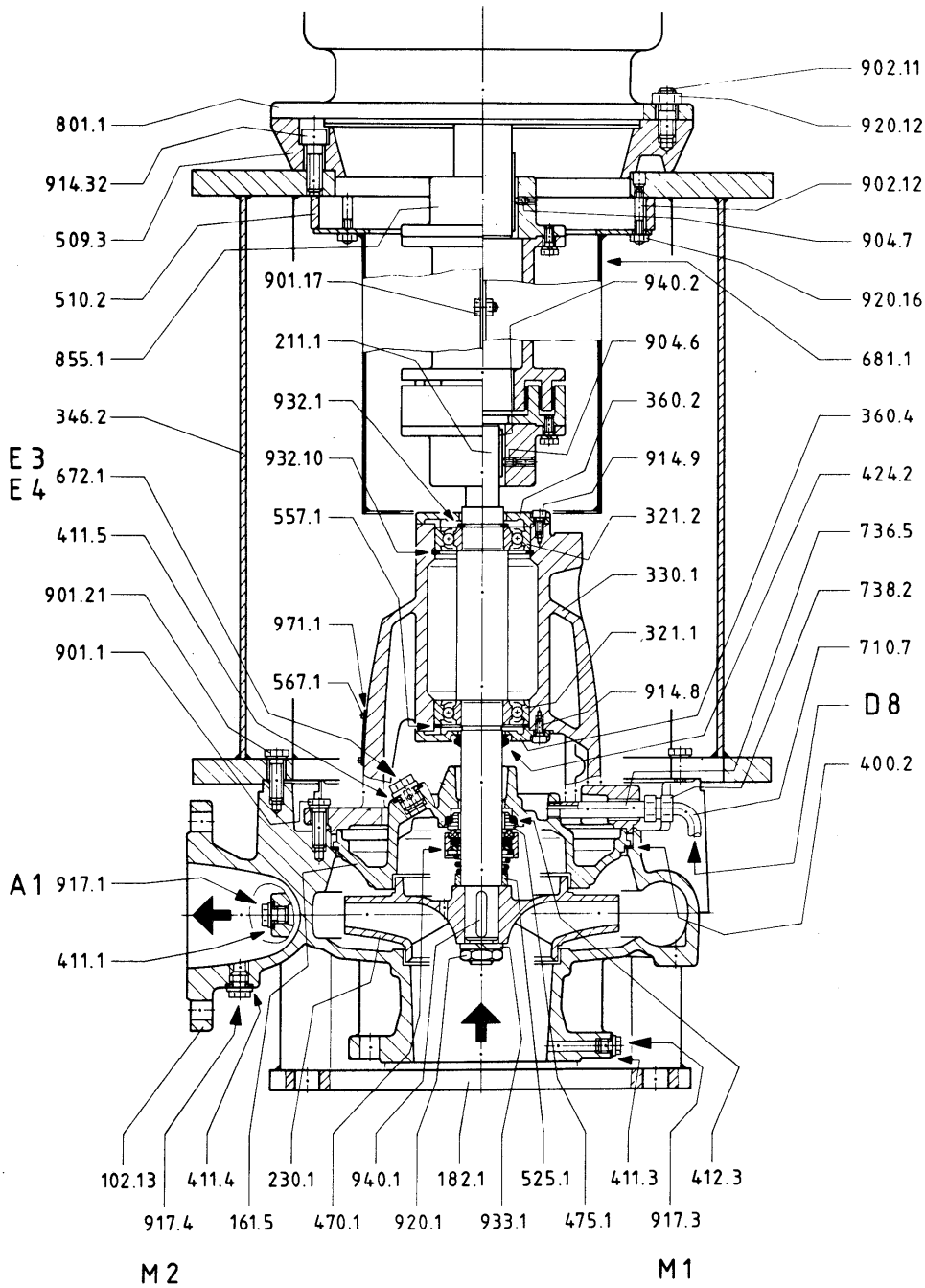

Shaft sealing: Uncooled, unbalanced mechanical seal, internal flushing
 Abbreviation: U3D

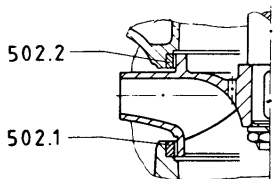

Design with split rings V2 (surcharge)

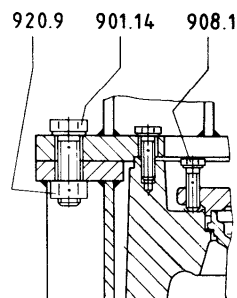

Fixture of pump feet to pump bracket

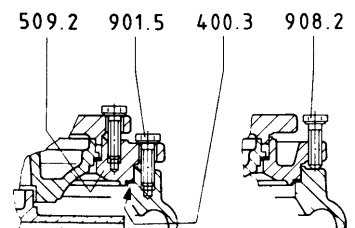

Model with intermediate ring

View Wall Mounting Type

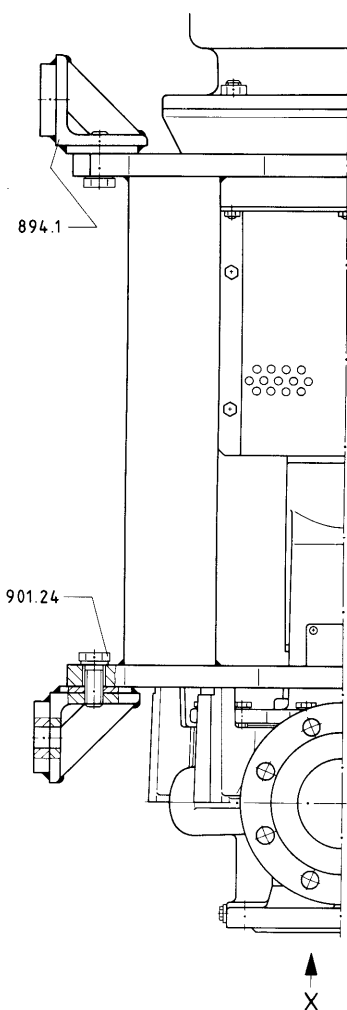

View X

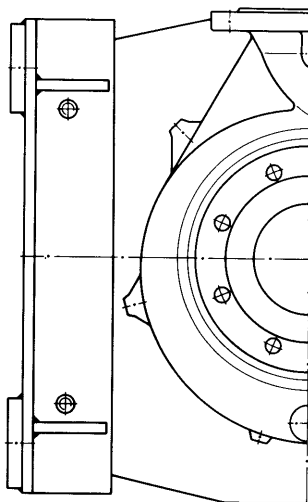

List of components for pedestal mounting and wall fastening

Denomination	Part No.	Denomination	Part No.
Volute casing	102.13	Pipe	710.7
Casing cover	161.5	Nipple joint	736.5
Casing cover	161.23	Screw-on type union	738.2
Pump foot	182.1	Motor	801.1
Shaft	211.1	Dismounting-type coupling	855.1
Impeller	230.1	Bracket	894.1
Grooved ball bearing	321.1	Hexagonal screw	901.1
Grooved ball bearing	321.2	Hexagonal screw	901.5
Bearing bracket	330.1	Hexagonal screw	901.14
Pump spacer	346.2	Hexagonal screw	901.17
Bearing cover	360.2	Hexagonal screw	901.21
Bearing cover	360.4	Hexagonal screw	901.24
Gasket	400.2	Locking screw	902.4
Gasket	400.3	Locking screw	902.11
Washer	411.1	Locking screw	902.12
Washer	411.3	Stud	904.6
Washer	411.4	Stud	904.7
Washer	411.5	Forcing screw	908.1
O-ring	412.3	Forcing screw	908.2
V-ring	424.2	Socket head cap screw	914.8
Gland	452.1	Socket head cap screw	914.9
Seal ring	458.1	Socket head cap screw	914.32
Packing ring	461.1	Threaded plug	917.1
Mechanical seal	470.1	Threaded plug	917.3
Stationary seal ring	475.1	Threaded plug	917.4
Casing wear ring	502.1	Hexagonal nut	920.1
Casing wear ring	502.2	Hexagonal nut	920.2
Intermediate ring	509.2	Hexagonal nut	920.9
Intermediate ring	509.3	Hexagonal nut	920.12
Distance ring	510.2	Hexagonal nut	920.16
Distance sleeve	525.1	Circlip	932.1
Ball bearing balancing disc	557.1	Spring washer	933.1
Blind rivet	567.1	Key	940.1
Venting screw	672.1	Key	940.2
Coupling guard	681.1	Rating plate	971.1

Connections

- A1 Filling or control pressure extraction for automatic aspirator
- B1 Drainage
- D8 Leakage drain
- E3 Venting
- E4 Venting with automatic aspirator
- M1 Pressure gauge
- M2 Pressure gauge

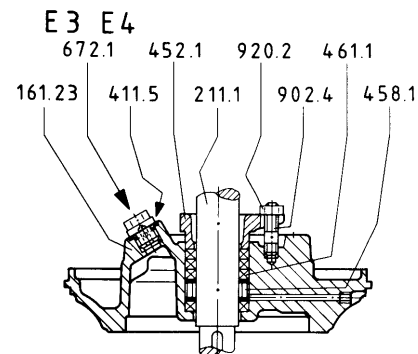

Stuffing box with internal sealing U1B

Unit dimensions - Pump with Inline Casing for Wall Mounting

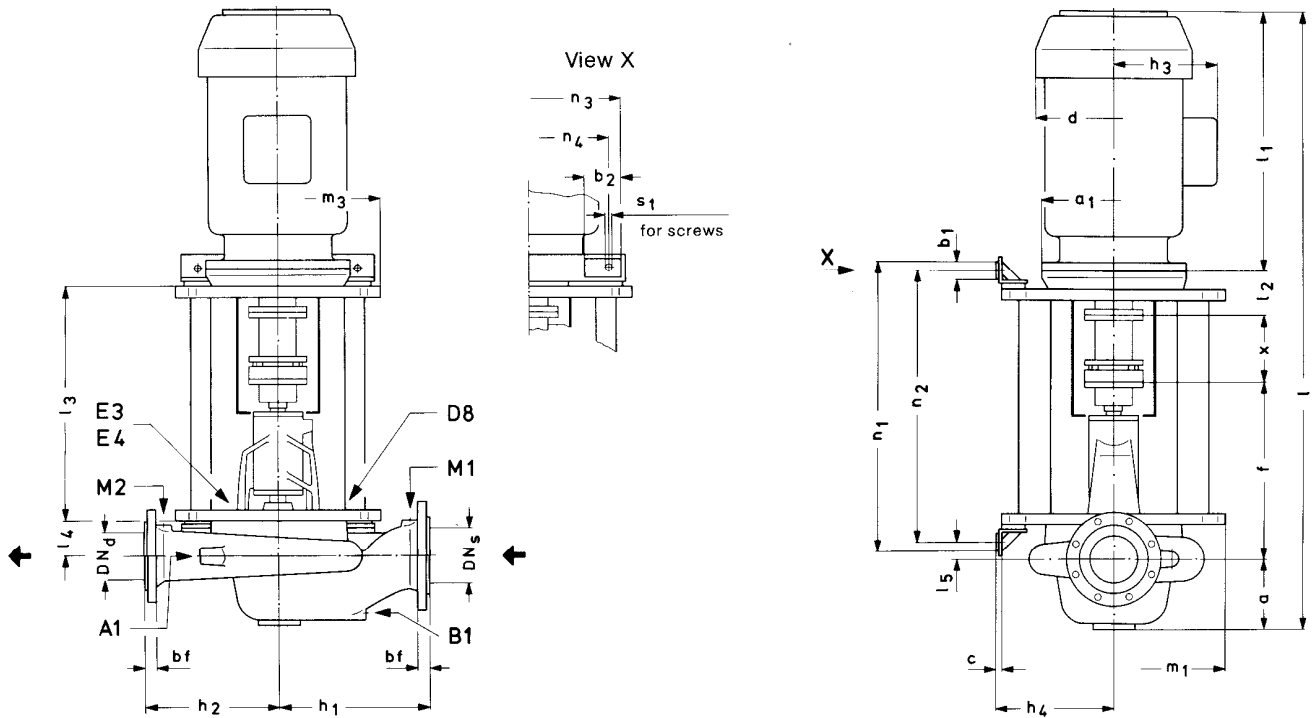

① The dimensions of fastening brackets of pump spacer size 470–250 do not apply to electric motors with flange size a₁ = 660 mm. In case of use of these electric motors or in case of combination with the above-mentioned pump spacer size, please inquire.

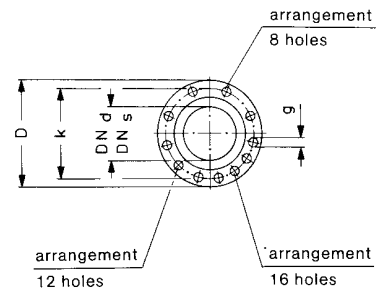

Size	Bearing bracket size	Pump spacer size	Unit dimensions																				
			Pump dimensions											Extension dimension X	Dimensions of fastening brackets								
			DN _s	DN _d	a	f	h ₁	h ₂	l ₃	l ₄	m ₁	m ₃	b ₁		b ₂	c	h ₄	l ₅	n ₁	n ₂	n ₃	n ₄	s ₁
65-250	470	470-250 ①	100	80	135	470	355	350	585	86	600	550	140	80	100	29	335	29	780	700	520	460	M20
65-315	470	470-315	100	80	135	470	385	375	601	70	650	590	140	80	100	29	355	13	795	715	570	510	M20
65-400	470	470-400	100	80	136	470	425	415	601	70	700	615	140	80	100	29	405	13	795	715	620	560	M20
80-200	470	470-250 ①	125	100	144	470	360	350	585	86	600	550	140	80	100	29	335	29	780	700	520	460	M20
80-250	470	470-250 ①	125	100	144	470	360	350	585	86	600	550	140	80	100	29	335	29	780	700	520	460	M20
80-315	470	470-315	125	100	144	470	390	375	601	70	650	590	140	80	100	29	355	13	795	715	570	510	M20
80-400	530	530-400	125	100	146	530	450	435	666	105	790	615	180	80	100	29	410	48	860	780	670	610	M24
100-200	470	470-250 ①	150	125	173	470	380	350	585	86	600	550	140	80	100	29	335	29	780	700	520	460	M20
100-250	470	470-250 ①	150	125	173	470	400	350	585	86	600	550	140	80	100	29	335	29	780	700	520	460	M20
100-315	470	470-315	150	125	175	470	425	420	601	70	650	590	140	80	100	29	355	13	795	715	570	510	M20
100-400	530	530-400	150	125	176	530	450	435	666	105	790	615	180	80	100	29	410	48	860	780	670	610	M24
125-250	470	470-250 ①	200	150	199	470	440	355	585	86	600	550	140	80	100	29	335	29	780	700	520	460	M20
125-315	530	530-315	200	150	201	530	440	390	666	105	710	615	180	80	100	29	370	48	860	780	595	535	M24
125-400	530	530-400	200	150	202	530	470	450	666	105	790	615	180	80	100	29	410	48	860	780	670	610	M24
150-250	530	530-315	250	200	270	530	480	400	666	105	710	615	180	80	100	29	370	48	860	780	595	535	M24
150-315	530	530-315	250	200	231	530	465	450	666	105	710	615	180	80	100	29	370	48	860	780	595	535	M24
150-400	530	530-400	250	200	229	530	500	500	666	105	710	615	180	80	100	29	410	48	860	780	670	610	M24
200-250	530	530-250	250	250	270	530	520	480	641	130	810	615	180	80	100	29	420	73	835	755	595	535	M24
200-315	585	585-400	300	250	276	585	580	480	860	146	1000	800	300	120	180	32	538	61	1150	1030	780	660	M30
250-315	585	585-400	350	300	323	585	665	600	860	146	1000	800	300	120	180	32	538	61	1150	1030	780	660	M30
250-400	585	585-400	350	300	336	585	700	600	860	146	1000	800	300	120	180	32	538	61	1150	1030	780	660	M30

Unit dimensions for Pedestal Mounting

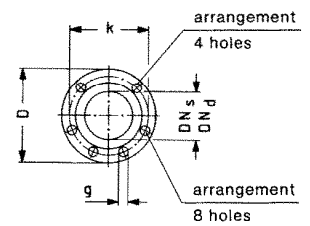
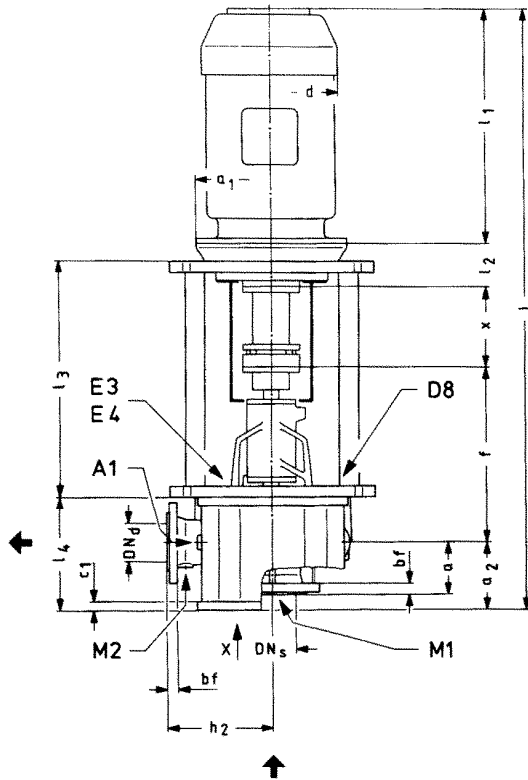

Dimension of feet
in X direction

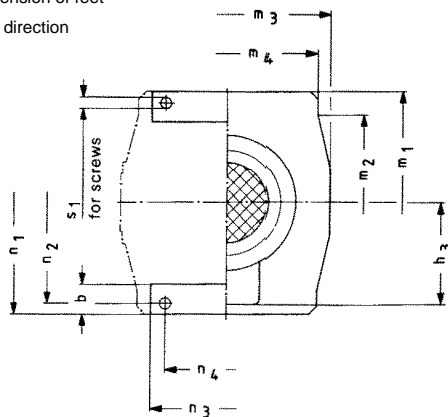

Dimension in mm
Subject to alterations.

Sense of rotation: clockwise seen
from driving side

Size	Bearing bracket size	Pump spacer size	Unit dimensions																			
			Pump dimensions													Extension dimensions	Dimensions of fastening bracket					
			DN _s	DN _d	a	a ₂	f	h ₂	l ₃	m ₁	m ₂	m ₃	m ₄	X	b		c ₁	l ₄	n ₁	n ₂	n ₃	n ₄
65-250	470	470-250	80	65	100	170	470	250	585	600	476	550	480	180	80	18	296	600	540	400	330	M20
65-315	470	470-315	80	65	125	145	470	280	601	650	525	590	535	180	80	18	255	650	590	450	380	M20
80-250	470	470-250	100	80	125	170	470	280	585	600	476	550	480	180	80	18	296	600	540	400	330	M20
80-315	470	470-315	100	80	125	145	470	315	601	650	525	590	535	180	80	18	255	650	590	450	380	M20
100-250	470	470-250	125	100	140	170	470	280	585	600	476	550	480	180	80	18	296	600	540	400	330	M20
100-315	470	470-315	125	100	140	145	470	315	601	650	525	590	535	180	80	18	255	650	590	450	380	M20
125-250	470	470-250	150	125	140	170	470	355	585	600	476	550	480	180	80	18	296	600	540	400	330	M20

Unit dimensions for Wall Mounting

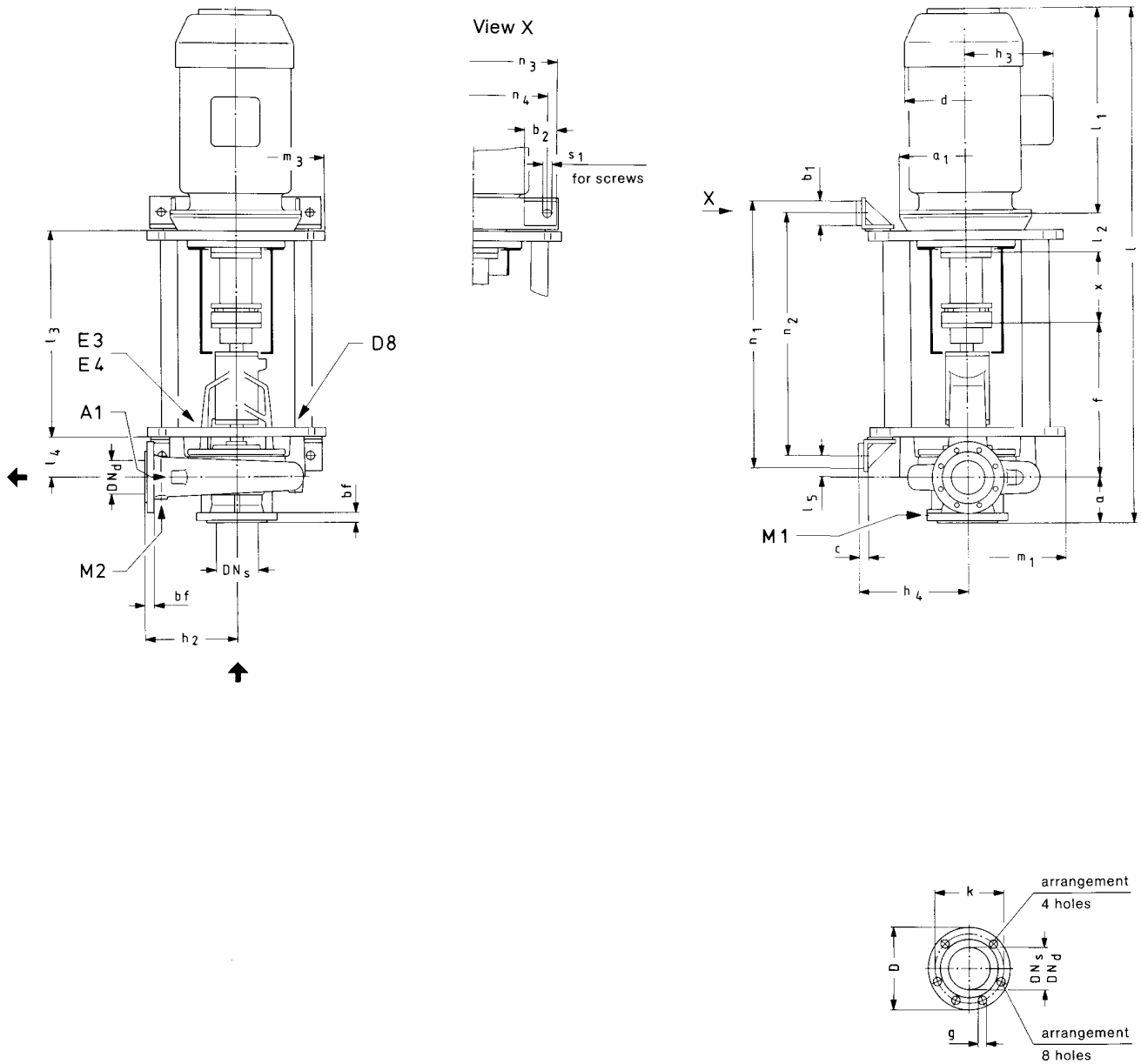

Dimension in mm
Subject to alterations.

Sense of rotation: clockwise seen
from driving side

Size	Bearing bracket size	Pump spacer size	Unit dimensions																			
			Pump dimensions										Extension dimensions X	Dimensions of fastening brackets								
			DN _s	DN _d	a	f	h ₂	l ₃	l ₄	m ₁	m ₃	b ₁		b ₂	c	h ₄₄	l ₅	n ₁	n ₂	n ₃	n ₄	s ₁
65-250 65-315	470 470	470-250 470-315	80 80	65 65	100 125	470 470	250 280	585 601	126 110	600 650	550 590	180 180	80 80	100 100	29 29	335 355	69 53	780 795	700 715	520 570	460 510	M20 M20
80-250 80-315	470 470	470-250 470-315	100 100	80 80	125 125	470 470	280 315	585 601	126 110	600 650	550 590	180 180	80 80	100 100	29 29	335 355	69 53	780 795	700 715	520 570	460 510	M20 M20
100-250 100-315	470 470	470-250 470-315	125 125	100 100	140 140	470 470	280 315	585 601	126 110	600 650	550 590	180 180	80 80	100 100	29 29	335 355	69 53	780 795	700 715	520 570	460 510	M20 M20
125-250	470	470-250	150	125	140	470	355	585	126	600	550	180	80	100	29	335	69	780	700	520	460	M20

Flanges acc. to DIN 2533					
DN _s /DN _d	D	bf	k	g	No. of holes
65	185	20	145	18	4
80	200	22	160	18	8
100	220	24	180	18	8
125	250	26	210	18	8
150	285	26	240	22	8

Connections					
Filling	Leakage-drain	Venting		Pressure gauge	
		E3	autom. aspirat. E4	M1	M2
A1	D8	E3	G 1/2	M1	M2
G 3/8	G 3/8	G 3/8	G 1/2	G 1/4	G 3/8

Possible driving motors and allocation to pump sizes.

The motor dimensions as indicated are approximate values. Exact data depend on the motor make.

In case of drive powers of over 132 kW, please inquire in any event as the motor connection dimensions are not standardized.

Extension possibilities of the slide-in unit

Pump spacer size	Extension possibility	
	I	II
470-250 470-315	x	x

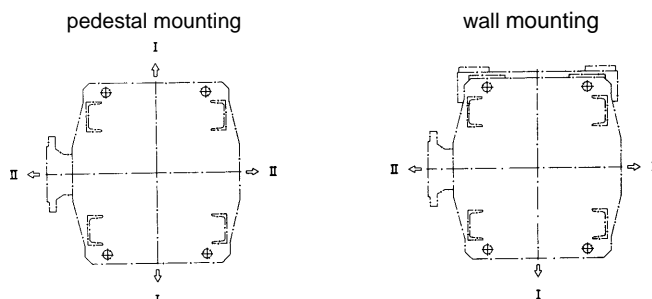

When using special marine motors, care must be taken that depending upon the enclosures different performances are allocated to the individual sizes. The main dimensions are changed accordingly. In case of order, binding motor dimension sheets are to be transmitted to us.

Speed	Motor size	Adapted for attachment to bearing bracket	kW	a ₁	d	h ₃	l ₁	l ₂	I	Pump size															
										65-250	65-315		80-250	80-315		100-250	100-315	125-250							
1450/ 1750 1/min	100 L	470	2,2	250	200	140	302	60	I = a+f+x+l ₂ +l ₁																
			3																						
	112 M	470	4	300	224	152	323	60																	
			5,5																						
	132 S	470	7,5	350	260	185	411	80																	
			11																						
	132 M	470	15	330	255	527	110	110																	
			18,5																						
	160 M	470	22	350	330	255	553	110																	
			18,5																						
160 L	470	30	400	363	316	631	110																		
		37																							
180 M	470	45	450	399	337	664	140																		
		45																							
200 L	470	55	550	443	377	752	140																		
		55																							
2900/ 3500 1/min	100 L	470	3	250	200	140	302	60	I = a+f+x+l ₂ +l ₁																
	112 M	470	4	250	224	152	323	60																	
	132 S	470	5,5	300	220	165	354	80																	
			7,5																						
	160 M	470	11	350	260	185	446	110																	
			15																						
	160 L	470	18,5	330	255	527	110	110																	
			22																						
	180 M	470	30	400	363	316	631	110																	
			37																						
225 M	470	45	450	399	337	664	110																		
		45																							
250 M	470	55	550	443	377	752	140																		
		55																							
280 S	470	75	550	496	409	852	140																		
		90																							
315S	470	110	660	684	470	957	140																		

Automatic aspirator A 25 A

Series NIM with automatic aspirator A25A

The A 25 A is employed for the automatic venting of the pump and suction line. It operates with a pressure-dependent control system.

Owing to a pressure-controlled shut-off valve in the suction line, the device can also be used in plants in which excess pressure is temporarily incurred.

Functioning description:

By way of the vent line, suction branch Q2 of the automatic aspirator is coupled with connection E4 of the pump. The compressed air required for the venting process is supplied to the ejector at connection Q1.

To avoid any dry operation of the pump, the electric circuitry (not included in the normal scope of supplies) must be such that the pump is started only after the entire suction system has been vented.

As soon as a discharge pressure has been set up and the preset pressure limit reached, the automatic aspirator is switched off by the pressure switch. The impulse is transmitted by way of the control pressure line coupling connection A1 at the pump with connection Q4 at the pressure switch.

The discharge pressure falling below the preset pressure limit, the automatic aspirator will be switched on again.

According to the respective operating conditions, the pressure switch should be adjusted so as to switch the automatic aspirator off at approx. 80% of the lowest pump discharge pressure, switching it on again at approx. 30%.

Required control voltage 220 V, 50 Hz or 60 Hz (80% duty cycle), special voltage on request. Power consumption during starting 22 VA, during operation 15 VA, enclosure IP 54.

Materials:

- Lower nozzle Plastic
- Upper nozzle: Plastic
- Inlet nozzle: G-CuZn 16Si4
- Pipes ①: Cu

① Coming into contact with the fluid to be pumped.

Driving air required at 6 bar operating pressure $Q = 0.28 \text{ m}^3/\text{min}$. The water-air mixture is drained by way of connection Q 3.

List of components for the attachment of the automatic aspirator A 25 A, Series NIM/NAM:

Denomination	Part No.
Washer	411.31
Washer	411.32
Washer	411.34
Reinforcing sleeve	532.1
Reinforcing sleeve	532.4
Reinforcing sleeve	532.5
Reinforcing sleeve	532.6
Automatic aspirator	675.1
Pipe	710.5
Pipe	710.6
Mount	732.2
Straight union	735.4
Straight union	735.6
Straight union	735.7
Threaded pipe angle	765.4
Hexagonal screw	901.20
Hexagonal screw	901.22
Hexagonal nut	920.15
Locking plate	935.4

Pump spacer size	Size A
470-250	400
470-315	430
470-400	470
530-250	435
530-315	435
530-400	475
585-400	505

Subject to technical alternations.

